

100kW Photovoltaic Energy Storage Battery Cabinet



100kW Photovoltaic Energy Storage Battery Cabinet



100kW x 215kWh Energy Storage Cabinet

The MEG 100kW x 215kWh Cabinet is engineered as a modular energy storage building block, ideal for commercial facilities, microgrids, and community-scale projects.

[Get Price](#)

Lithium-ion Battery Storage Technical Specifications

This document is meant to be used as a customizable template for federal government agencies seeking to procure lithium-ion battery energy storage systems (BESS).



[Get Price](#)



Sunway Intelligent liquid-cooled 100kW 232kWh Outdoor Cabinet Energy

Delivers 100 kW rated AC power and 232 kWh battery capacity for industrial and commercial energy needs. Designed with IP55 protection, transformer isolation, and real-time monitoring for enhanced ...

[Get Price](#)

Solar LiFePO4 100kwh Battery

Choose a 100kwh battery as a backup power source to solve energy worries completely. The Pknergy 100kWh battery cabinet is an integrated battery system that can provide reliable and ...

[Get Price](#)

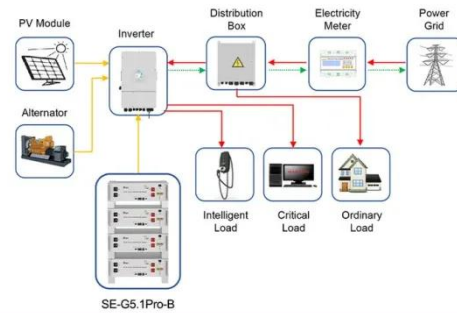

Application scenarios of energy storage battery products



100kW 215kWh All-in-One Battery Storage Cabinet

This industrial and commercial battery storage system is the ideal compact solution for your battery projects to work alongside solar PV, EV chargers and back up power requirements.

[Get Price](#)

100kWh Solar 280Ah LiFePO4 Battery, Air-cooling Energy ...

As the leading vertically integrated manufacturer of lithium iron phosphate battery systems, GSL ENERGY has provided various battery solutions for nearly all kinds of ESS applications.

[Get Price](#)

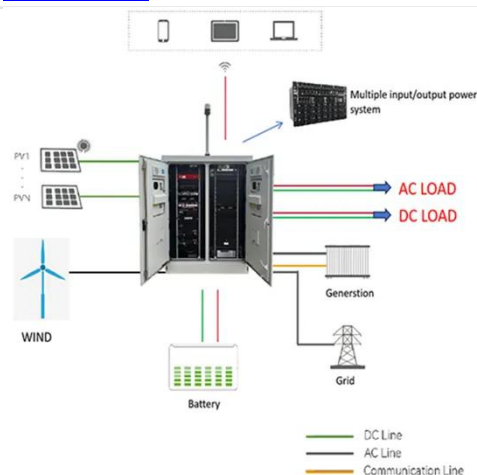

Power Your Future with 100kW Battery Storage: Discover Cost ...

...



This comprehensive guide will help you understand the key aspects of 100kW battery storage systems, including design considerations, budget estimates, and selection tips to ensure you make an ...

[Get Price](#)

100 KWh-500KWh Solar Battery Storage Cabinet, 100kWh ...

This integrated solar battery storage cabinet is engineered for robust performance, with system configurations readily scalable to meet demands such as a 100kwh battery storage requirement.



[Get Price](#)



100KW Lithium Ion Battery Storage Cabinets

Configured with a rack-mounted modular PCS, it supports parallel connection of multiple machines and has good scalability; the number of PCS modules and the total battery power can be selected ...

[Get Price](#)

HUA POWER C & I BESS

Cabinet - 100kW/215kWh PV + Battery ...

With 100kW PCS and 215kWh of LiFePO4 battery storage, it delivers robust, efficient, and versatile energy management. This solution integrates advanced BMS and EMS technologies to provide real ...

[Get Price](#)



Contact Us

For catalog requests, pricing, or partnerships, please visit:
<https://www.cannabiswow.es>

